

**A UNIVERSAL &  
INNOVATIVE  
SYSTEM FOR  
THE ENERGY  
MANAGEMENT**

# NEMO SX



# ENERGY EFFICIENCY

EFFECTIVE ACTION  
TAKEN TO ENSURE  
ENERGY EFFICIENCY  
NOT ONLY REDUCES  
ENERGY CONSUMPTION  
AND GREENHOUSE GAS  
EMISSIONS, BUT  
ALSO YIELDS  
FINANCIAL BENEFITS  
**AS WELL  
AS EASIER  
USE AND  
FUNCTION OF  
INSTALLATIONS.**



# CONTENTS

- 03 THE IME SOLUTIONS
- 04 THE ENERGY MANAGEMENT
- 05 ACTIONS AND FUNCTIONS
- 06 ADVANTAGES
- 08 NEMO SX - A NEW SUPERVISION SYSTEM
- 10 A COMPLETE AND COMPACT SYSTEM
- 12 SIMPLE TO CHOOSE
- 14 SIMPLE TO CONFIGURE AND ADAPTABLE FOR ALL INSTALLATIONS
- 16 APPLICATION EXAMPLES
- 20 CATALOGUE PAGES



The NEMO SX IME  
**ENERGY  
MANAGEMENT**

system was created to supervise and manage energy consumption within the building, guaranteeing reliability and continuity of service for maximum efficiency.



**KNOWING**  
ENERGY CONSUMPTIONS  
is the FIRST STEP  
towards energy efficiency.

**CONTROLLING THEM**  
is the SECOND, ...

# The **IME** solutions

IME offers various solutions by which to **MEASURE and SUPERVISE** electrical systems that can adapt to all needs and ensure their full control and management.

The versatility of the IME solutions guarantees their interfacing with other ENERGY MANAGEMENT systems.



---

## SIMPLE INSTALLATIONS THAT MEASURE CONSUMPTION

devices for the measurement of electrical magnitudes and data collection.

## AUTOMATED INSTALLATIONS

devices for monitoring and automating distribution panels to guarantee continuity of service and a timely control of the installation.

## INSTALLATIONS CENTRALISÉES

systems for the all-round supervision of installations, able to offer all functions to allow for the optimal management of all devices.



# ENERGY MANAGEMENT

## the actions...

The **NEMO SX IME** energy management system allows you to control your installation in only a few steps.



### — set

Set the system with functions that are customised to your needs.



### — configure

Programme all devices, locally and remotely, to be able to dialogue both with them and with other external systems.



### — supervise

Monitor and control all processes by means of IT instruments to optimise energy consumption any time, anywhere.

# ... and the functions



## register

Register the consumption of all the users of the installation.



## measure

Measure analogue or electrical magnitudes (current, voltage, power, etc...).



## signalling

Display the status of electrical protection devices or circuits, both locally and remotely.



## control

Operate electrical protection devices or motorized controls, both locally or remotely, by means of manual or automatic actions.



## communicate

Send all information remotely, out of the electrical switchboard.



## display

Display the data locally or remotely, on built-in screens or on PCs, smartphones or tablets with an Internet connection.

# ENERGY MANAGEMENT advantages

The **NEMO SX** energy management system allows for the precise management and use of energy within a building. It allows full control of all activities in order to improve their functioning by anticipating possible breakdowns.

Counting and measuring consumptions to  
**REDUCE COSTS**



- **be aware** of its consumption;
- **control** consumptions;
- **adopt** a constant operating regime to smooth consumption over time.

Monitor and control the installation status to  
**ENSURE  
CONTINUITY OF  
SERVICE**



- **visualize** and assess technical alarms in real time;
- **know** installation status;
- **prevent** damage to parts of the installation.

Analyse data to  
**IMPROVE  
PROCESSES**



- **determine** annual energy needs to define a distribution of consumption;
- **analyse** the trend over time to control performance;
- **log** events to prevent critical issues.



# MAXIMUM NUMBER OF FUNCTIONS AND ACTIONS = MINIMUM NUMBER OF INTERVENTIONS AND CONSUMPTION

In an electrical infrastructure, having more functions and actions reduces the number of human interventions and makes a major contribution to **optimising final consumption**.

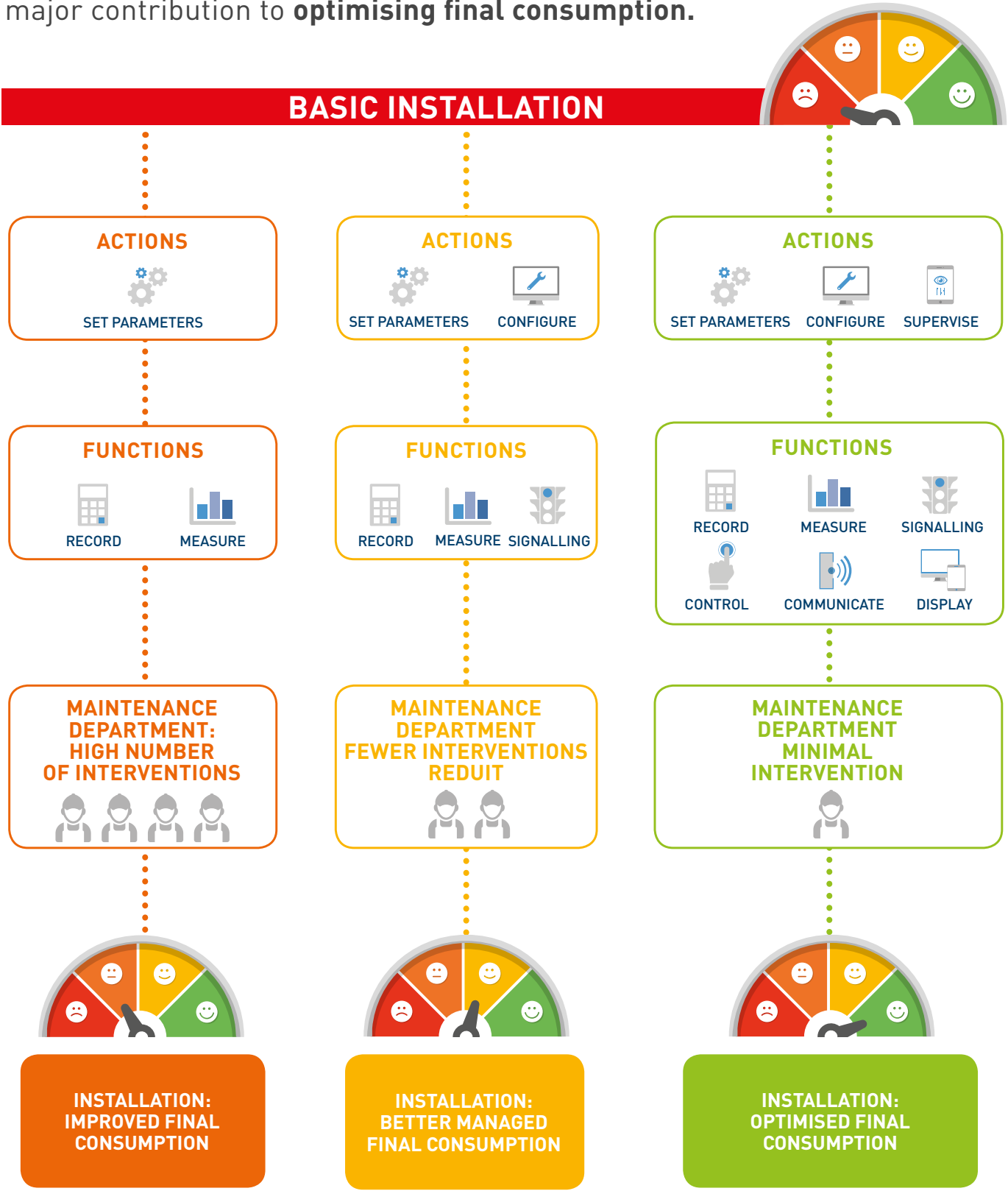

# NEMO SX

## a new supervision system

### **NEMO SX IS THE NEW SIMPLIFIED SUPERVISION SYSTEM**

able to display, measure and control the installation from a remote or local position. An autonomous system able to be integrated, which, thanks to the innovative automatic connection system, simplifies the assembly stages and requires no change in the wiring of existing panels.

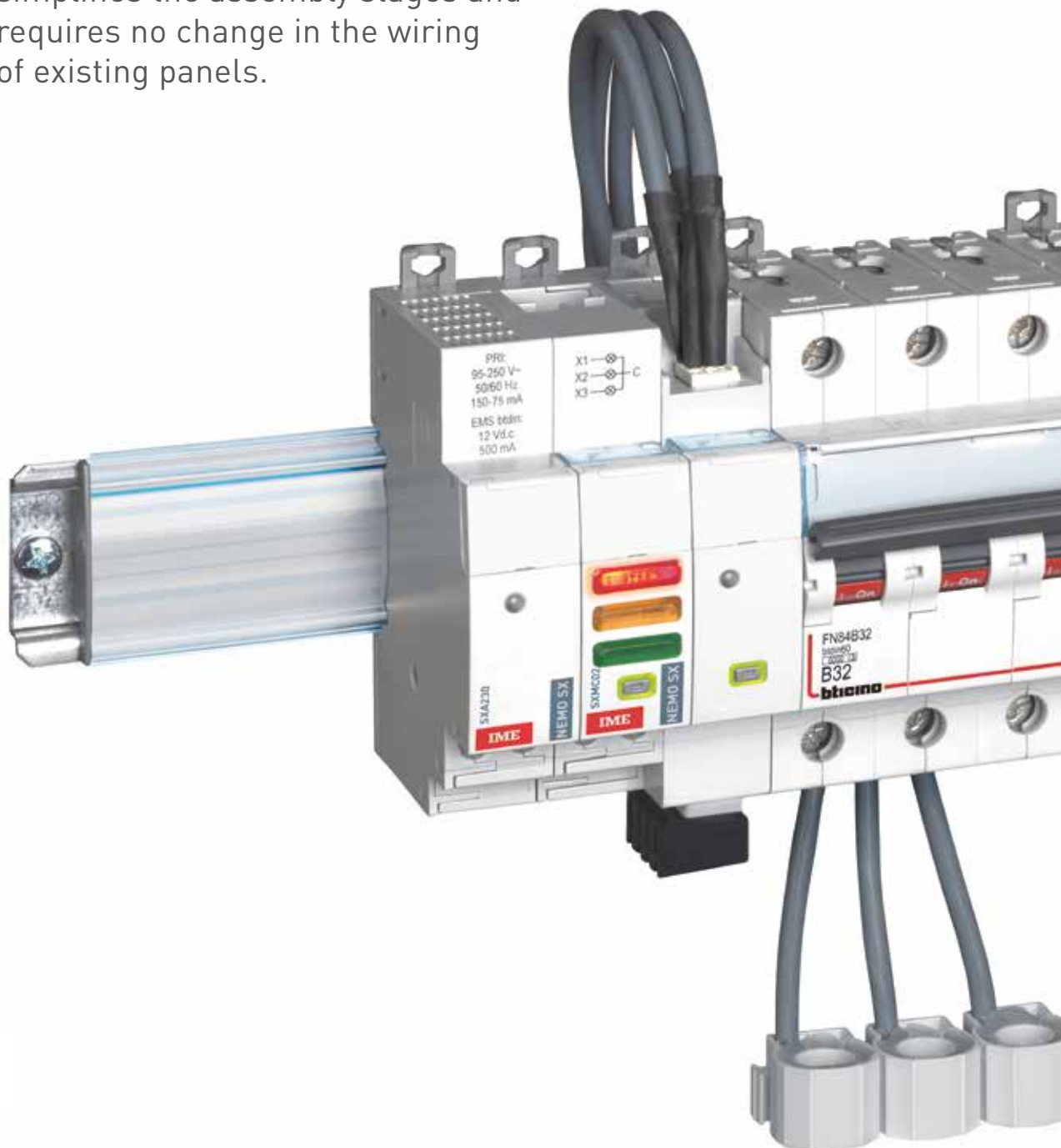

## COMPLET AND COMPACT

The new **NEMO SX supervision system**, with its extremely compact design, can offer all functions to allow for complete installation supervision:

- measurement
- status (ON/OFF/fault)
- control
- pulse count
- serial communication
- display

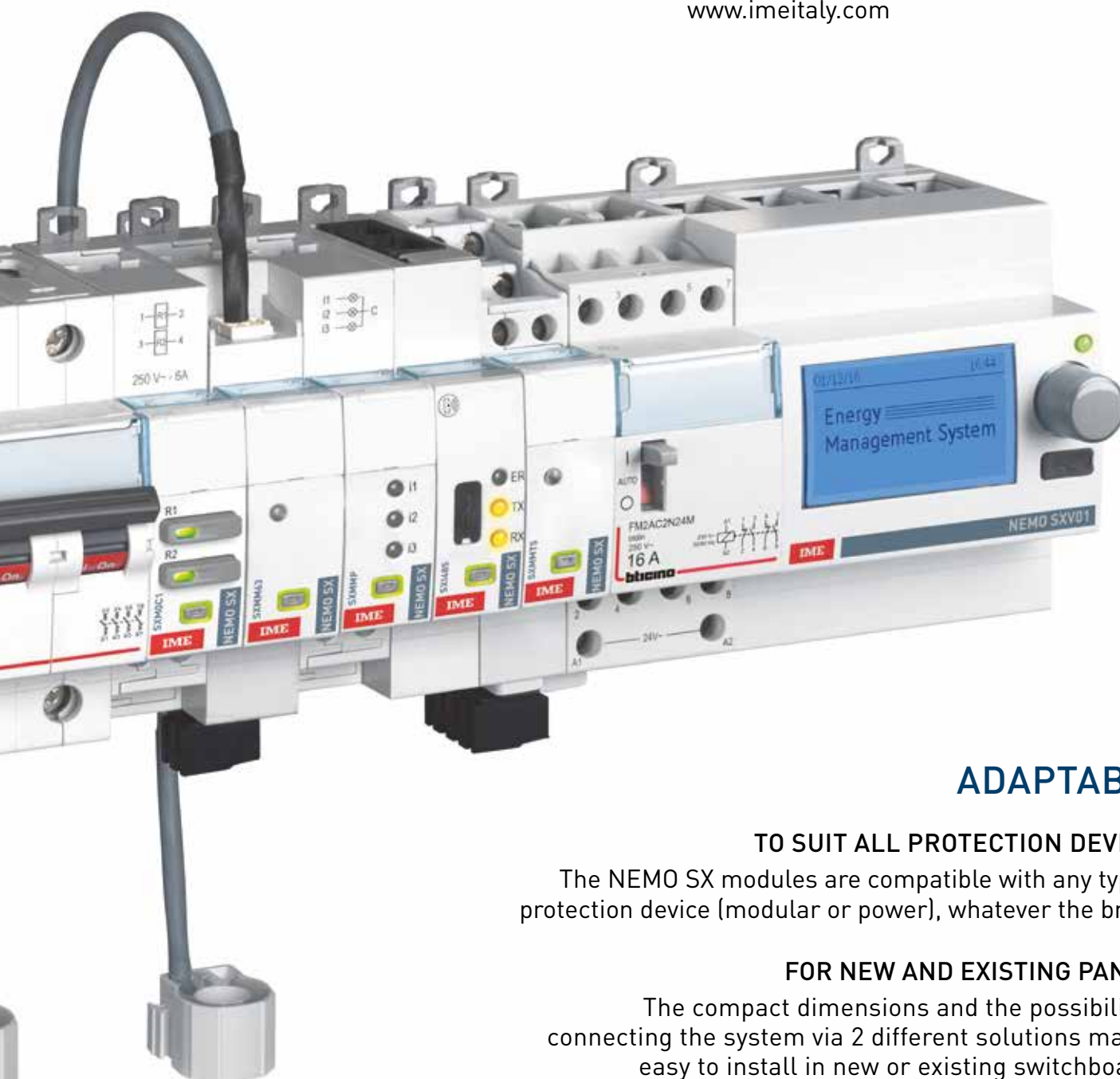

## SIMPLE

### SIMPLE TO CHOOSE

Only 8 modules with dedicated functions to supervise all installations.

### SIMPLE TO INSTALL

Quick, pre-cabled connections on rail or with patch cords that do not hinder electrical switchboard cabling.

### SIMPLE TO CONFIGURE

Configuration both directly from the panel without the help of a PC and via dedicated software that can be downloaded from [www.imeitaly.com](http://www.imeitaly.com)

## ADAPTABLE

### TO SUIT ALL PROTECTION DEVICES

The NEMO SX modules are compatible with any type of protection device (modular or power), whatever the brand.

### FOR NEW AND EXISTING PANELS

The compact dimensions and the possibility of connecting the system via 2 different solutions make it easy to install in new or existing switchboards.

# NEMO SX

complete, compact  
and multifunctional



## MEASUREMENT

## SIGNALLING



With the same performance as the "classic" models of measuring units, the NEMO SX measuring modules can be used to measure the electrical energy consumed by a single-phase or three-phase circuit and the different electrical values:

- Active (kW), reactive (kVAR) and apparent (kVA) power on all phases or cumulative
- Simple and compound voltages
- Current consumption on each phase
- Frequency and  $\text{Cos}\phi$
- Harmonics

Concentrator module for energy count by means of pulses: collects data from meters with pulse output like electrical energy meters or water and gas meters.... Up to 3 pulse circuits.

Compact modules indicating the status of the associated device: Contacts:

- open
- closed
- triggered

In addition, for the LED version:

- MCCB plugged-in / drawn-out
- springs loaded for opening / closing of ACBs

All the modules of the new **NEMO SX** supervision system have compact dimensions, in order to limit as much as possible the space used in the electrical switchboard.

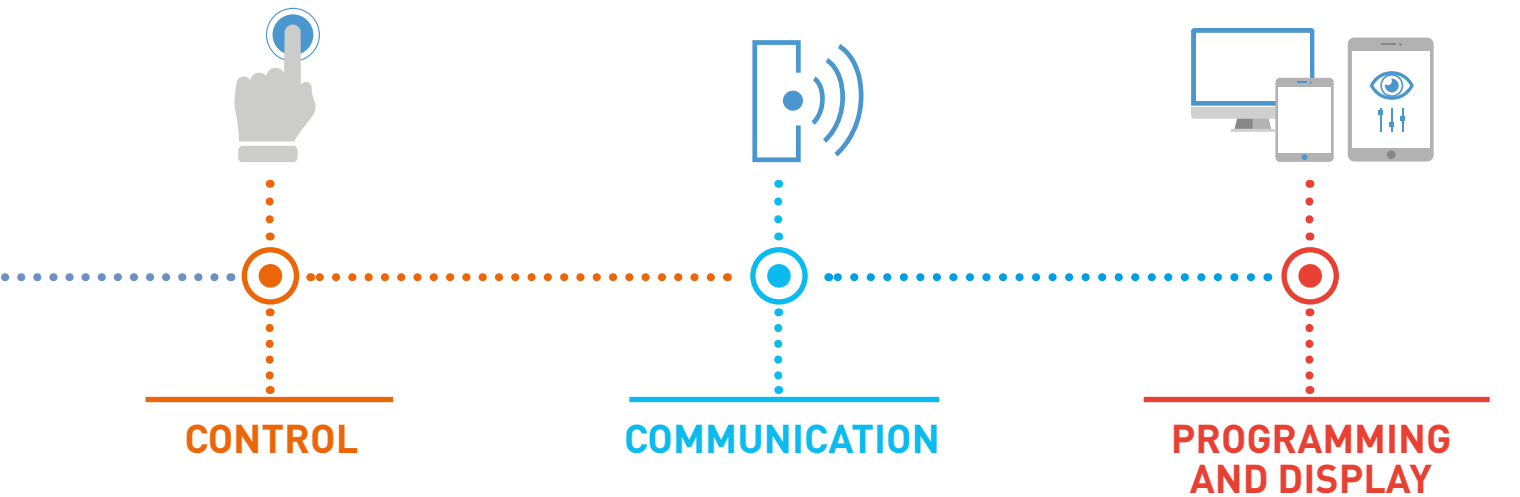

Universal control module. Enables to remotely control different electrical loads such as relays, contactors, and motorised controls of modular or power circuit breakers, whatever their brand.

The NEMO SX / RS 485 communication interface allows the conversion of data from the NEMO SX network to the MODBUS RS 485 network, in order to display and operate the data outside the electrical enclosure.

Stand alone configuration module for the control of the entire installation, locally, in the enclosure:

- system configuration
- test
- consumption display
- alarm control
- device control
- memory storage of the alarms

# NEMO SX

## simple to choose...

The **NEMO SX** system consists of DIN rail mounting modules.

The **NEMO SX** system does not require a minimum number of modules and it also allows very simple monitoring. Thanks to its scalability, new functions can be added at any time depending on the needs of the installation.

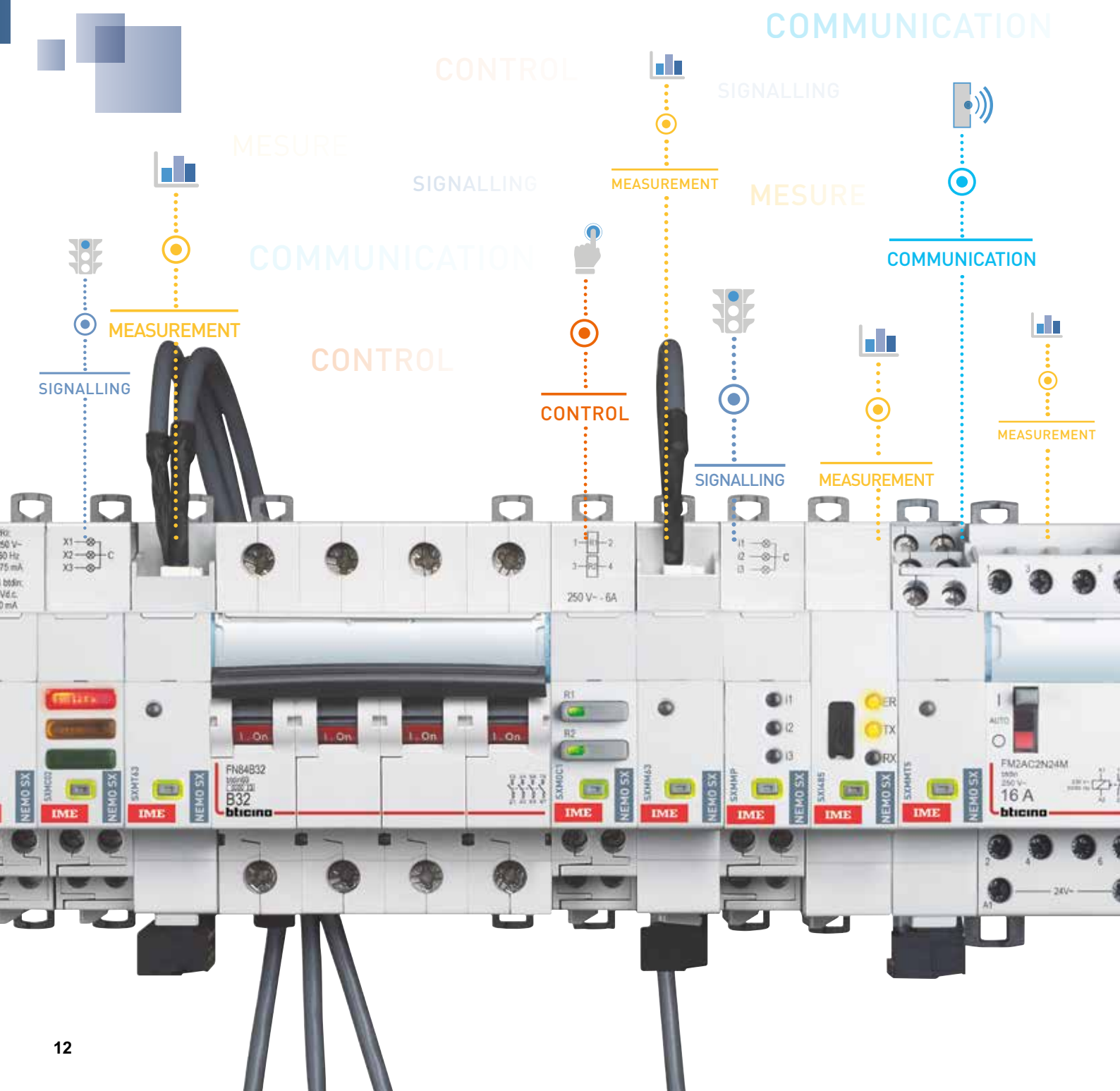

# ...simple to install

The **NEMO SX** system is powered at safety extra low voltage (SELV) and has 2 types of connection:

- by means of the innovative **communicaton rail** system
- by means of the quick fit **patch cords**.

## QUICK AND SIMPLE DATA CONNECTION

In both cases, the data connection is simple and immediate and **does not require any other additional space in the electrical enclosure**. In the case of the communication rail, the connection is made automatically via the rear contacts, when the NEMO SX modules are fixed on the DIN rail of the electrical panel.

### COMMUNICATION RAIL

Connection is made automatically with the connectors at the back side of the NEMO SX modules.



### PATCH CORDS

All NEMO SX modules are equipped at the bottom with ports for connection to the bus via dedicated patch cords.



# NEMO SX

## simple to configure

The **NEMO SX** system has been developed in order to be able to manage, simply and immediately, all functions, both from the electrical panel without using a PC and by means of a free of charge software with external devices.

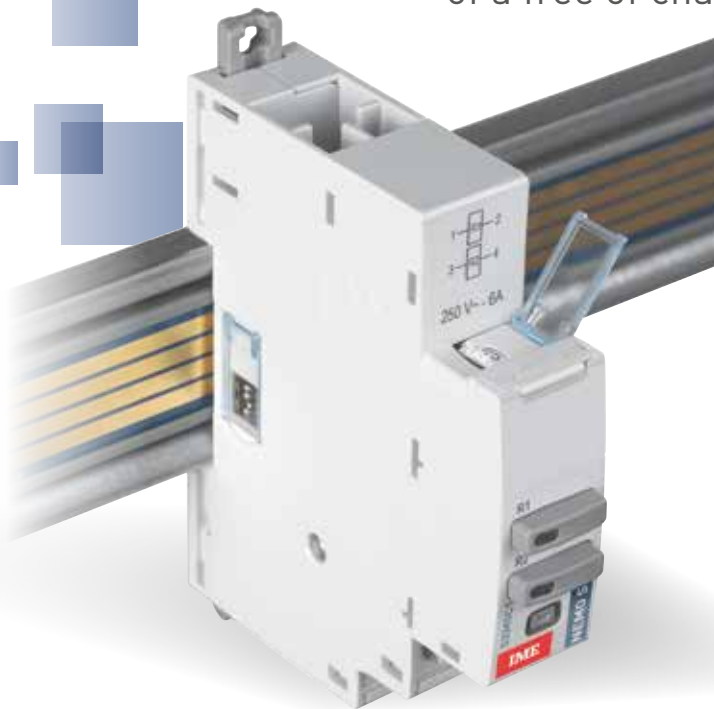

### PROGRAMMING AND DISPLAY

The stand alone NEMO SX configuration module allows to configure the system and to visualize all installed modules, without need of any IP or PC connection.



### FUNCTION CONFIGURATION

The universal signalling and control modules include 4 DIP switches that enable different function types to be set.



### ADDRESS CONFIGURATION

All modules are equipped with a selector for configuring the address locally. This configuration can also be done remotely via PC.



### FUNCTION

All modules are also equipped with a multifunction 3-colour LED button to instantly identify the operating status: correct operation, stand-by, being programmed, being updated, no NEMO SX communication, etc.





# adaptable for all installations

The **NEMO SX** modules are optimised for installation on DIN rail associated with MCBs, but can also manage power circuit breakers.



## SIGNALLING

The universal, configurable signalling module can be associated with all type of signalling auxiliaries of DIN rail mounting MCBs or power circuit breakers.



## CONTROL

Enables to locally or remotely control different electrical loads or motorised controls associated to DIN rail mounting protection devices or head equipment. Equipped with DIP switches (on the side) allowing product configuration:

- the contact type
- the function (maintained or momentary contact).



## MEASUREMENT

The high current measurement module with external CTs enables the measurement by means of CT with KTA ratio of up to 6400 A, which can therefore also be used in large power centre panels.

# NEMO SX

## application examples



### EXAMPLE 1 "STAND-ALONE" CONFIGURATION

IDEAL FOR INDIVIDUAL INSTALLATIONS WHERE THERE IS A LOCAL NEED TO:

- monitor parameters (electricity, water, gas, calories, etc.) of consumption and/or production
- check the status of various devices (switches, contactors, relays, end runs, etc.)
- locally control various devices (switches, contactors, relays, etc.)
- register alarms (up to 20)
- generate simple load control automations
- configure the installation simply

#### Scope of application:

Residential buildings and small commercial businesses potentially with photovoltaic and/or thermal solar energy production plants.

#### Installation

- maximum capacity for expansion: 32 devices
- maximum distance between two devices: 3 m
- maximum consumption of the entire system: 1500 mA, divided up into 3 inter-connected groups
- maximum consumption of each group: 500 mA supplied by a single power supply (Cat.No SXAA230)

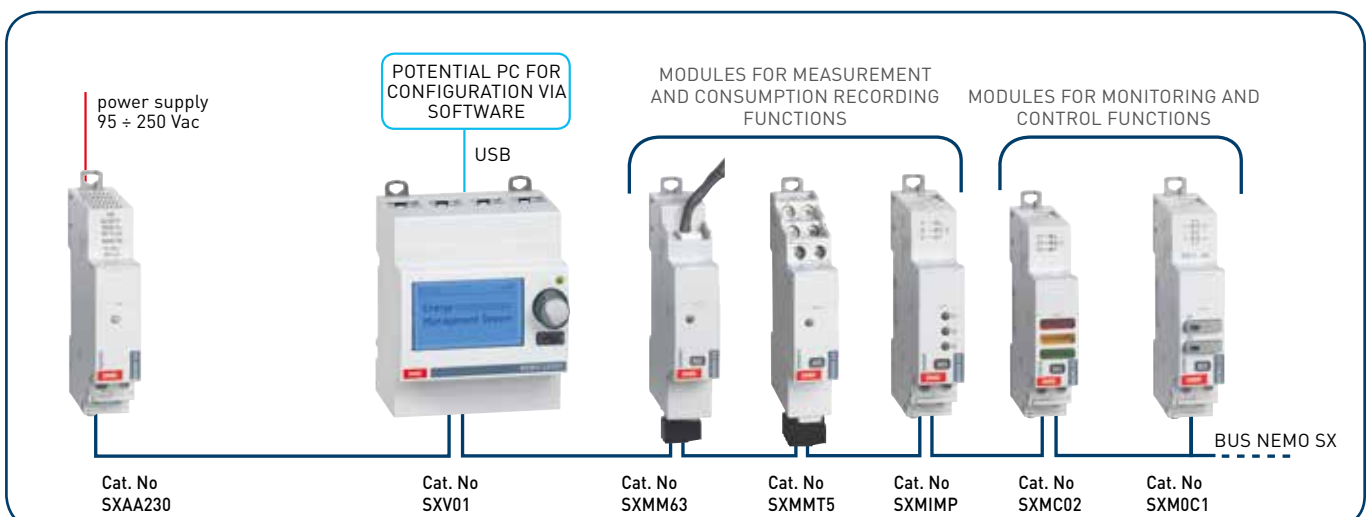



## EXAMPLE 2 CONNECTED CONFIGURATION

IDEAL FOR INDIVIDUAL INSTALLATIONS WHERE, IN ADDITION TO THE SERVICES DESCRIBED IN EXAMPLE 1, THE FOLLOWING IS REQUIRED:

- record the trend of various electrical parameters (voltage, current, power, power factor, frequency, harmonic distortion rate, etc.)
- create histograms and energy reports
- record events and alarms
- save data to files and automatically send out e-mails/text messages
- implement automation and load management systems
- access the system via various devices (smartphones, tablets, PCs, etc.)

### Scope of application:

Residential buildings and small commercial businesses where the need, above all, is to make installation monitoring and control possible from a remote position.

### Installation

- maximum expansion possible: 32 devices
- maximum distance between two devices: 3 m
- maximum consumption of the system: 1500 mA, divided up into 3 inter-connected groups
- maximum consumption of each individual group: 500 mA supplied by a single power supply (Cat.No SXAA230)

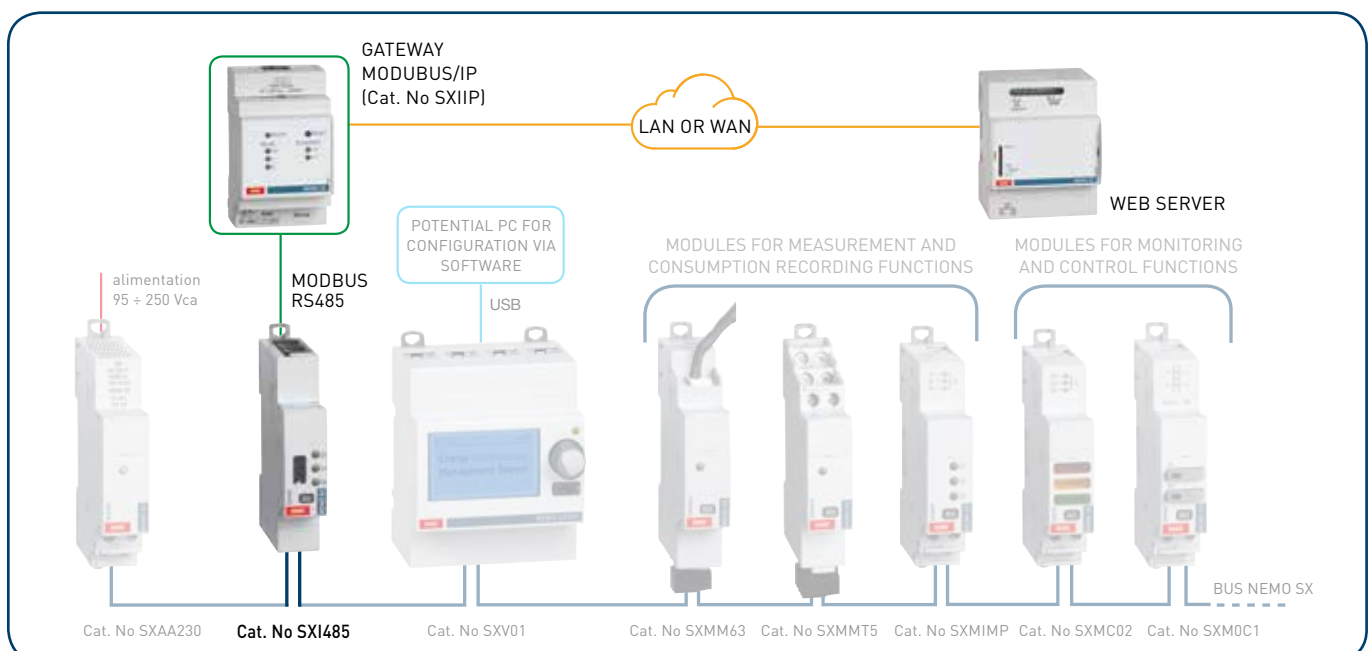

# NEMO SX

## application examples



### EXAMPLE 3 "ON-LINE" CONFIGURATION

IDEAL FOR INSTALLATIONS WHERE, IN ADDITION TO THE SERVICES DESCRIBED IN EXAMPLE 2, IT IS POSSIBLE TO INTEGRATE INDIVIDUAL BUS EMS SYSTEMS BETWEEN THEM AND OTHER MODBUS DEVICES ABLE, FOR EXAMPLE, TO:

- ensure additional measurement and control functions
- manage and monitor the parameters of the electronic protection relays typical of large switches (boxed and open)
- manage and monitor the automatic switching parameters between two power sources, etc.

#### Scope of application:

Buildings with simple installations, also consisting of several electric cabinets, with the need to control and monitor electrical loads.

#### Installation:

- maximum capacity for expansion: 32 MODBUS devices
- maximum length of RS485 bus: 1000 m
- maximum logical addresses: 247

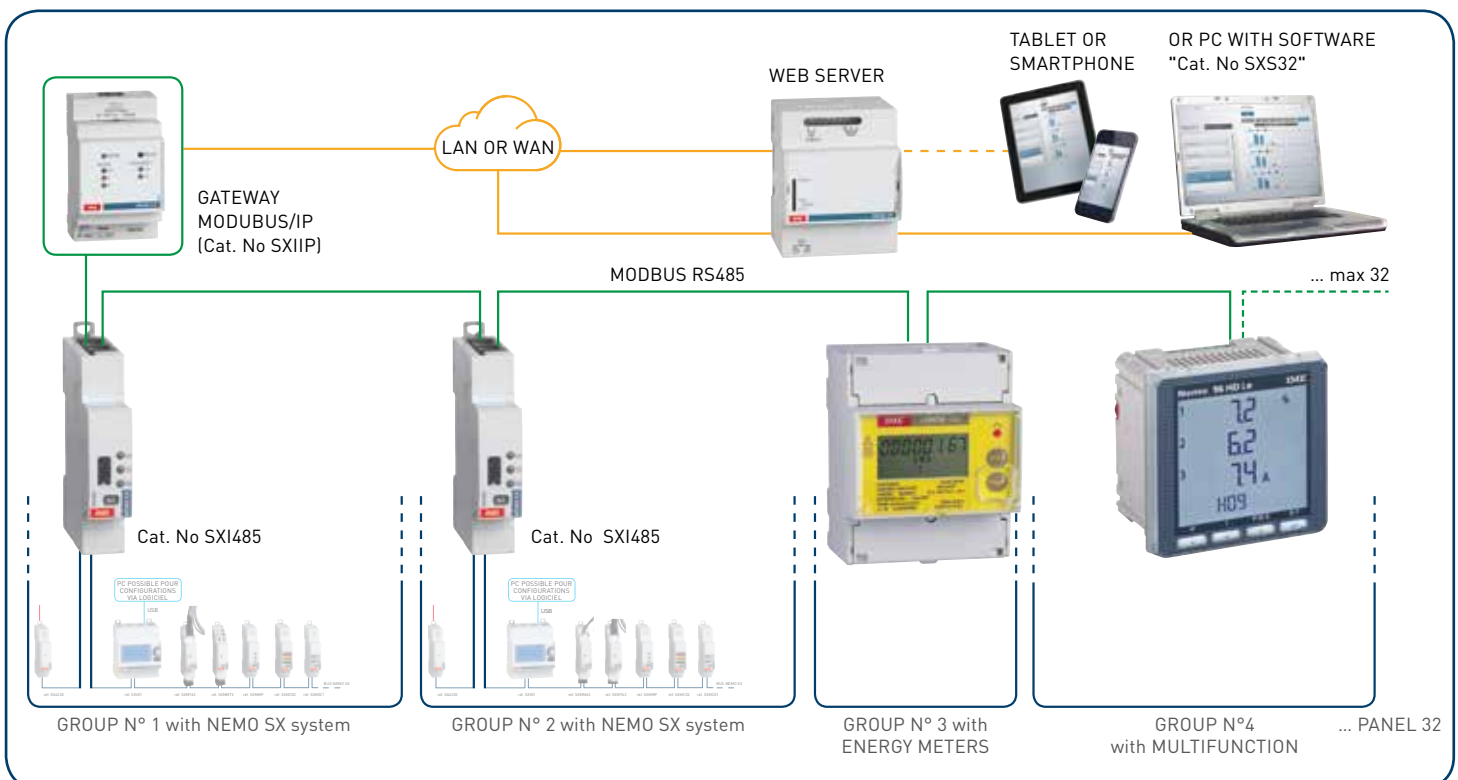



## EXAMPLE 4 "MULTI-SITE" CONFIGURATION

IDEAL FOR INDIVIDUAL PLANTS WHERE, IN ADDITION TO THE SERVICES DESCRIBED IN EXAMPLE 3, THE FOLLOWING IS REQUIRED:

- remotely manage individual installations situated in different locations with the help of devices (smartphone, tablet, PC, etc.) connected to the Internet
- have several levels of visualization: local (1 site) or remote, with a multi-site "administrator" view.

### Scope of application:

Sites (filiales de banques, points de vente de carburants, chaînes de magasin ou de restaurants, écoles, etc.) dotés d'installations simples, qui doivent être supervisées par une entité administratrice unique.

### Installation:

- maximum capacity for expansion: 32 MODBUS devices - 32 devices
- maximum length of bus RS485: 1000 m
- maximum logical addresses: 247

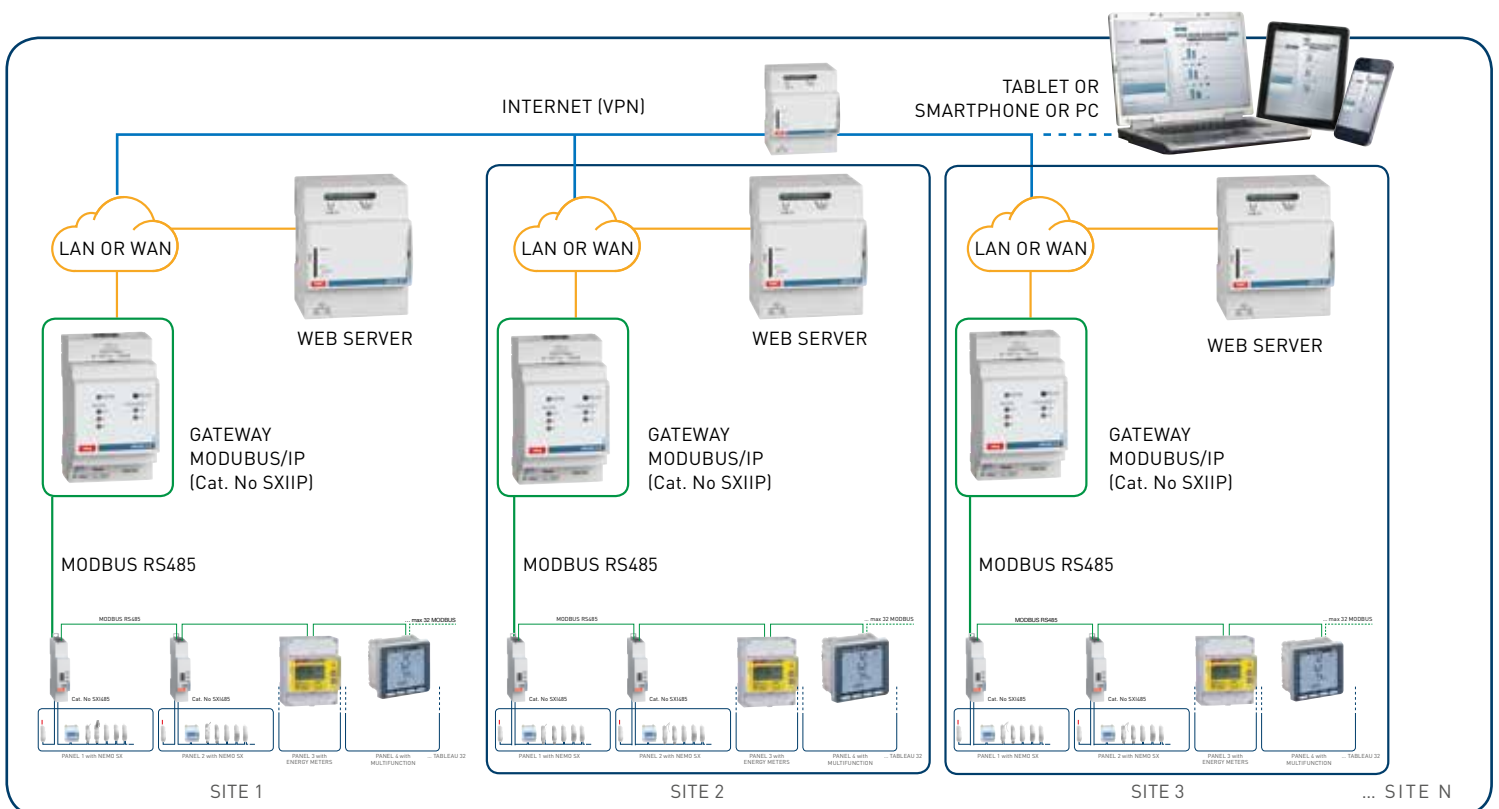

# NEMO SX: energy management system

## modules



Conform to IEC/EN 61131-2 (Programmable controllers)  
 NEMO SX energy management system enables to measure, control and visualize the state of 4 rail mounting protection devices (MCBs, RCCBs, RCBOs, etc...) and head equipment, locally ("Stand alone") or remotely. All the modules of the system are equipped with two specific communication ports: one at the backside (for communication rail) and one underneath (for communication patch cords). Power supply with specific module SXAA230.  
 Remote configuration possible with the help of the Energy Management Configuration Software, available for free download via IME WEB site (giving also access to a 30-day trial version of Energy Management Software)

Cat. No		Measurement modules	Cat. No	Universal control module	
		For measuring current, voltage, active/reactive power and other values Conform to IEC/EN 61557-12 Accuracy: class 0.5 <b>Direct connection up to 63 A</b> Measuring module and closed Rogowski coil up to 63 A		Enables to remotely control different electrical loads or motorised controls associated to rail mounting protection devices or head equipment. Equipped with DIP switches (on the side) allowing product configuration: contact type (NO + NC, 2 NO, etc...) and function (maintained or momentary contact)	
SXMM63		Single-phase measuring module and up to 63 A Consumption: 0.409 W - 34.1 mA (12 V =)	Number of modules 1	SXM0C1	2 relays: 240 V A - 6 A Consumption: 0.456 W - 38 mA (12 V =)
SXMT63		3-phase measuring module up to 63 A Consumption: 0.418 W - 34.8 mA (12 V =)	1		
		<b>Connection with CT</b> 5 A measuring module connected via current transformers (CT) Consumption: 0.391 W - 32.6 mA (12 V =)	1		
		<b>Pulse concentrator</b> For collecting and transmitting measurements taken by universal pulse energy meters (water, gas, etc...)	Number of modules 1		
SXMIMP		Up to 3 pulse circuits Consumption: 0.288 W - 24 mA (12 V =)	1		
		<b>State reporting module</b> <b>Universal signalling module</b> Indicates various type of information, according to selected configuration: contacts position, plugged-in or drawn-out product, etc... Equipped with DIP switches (on the side) allowing product configuration: selection of information type and of the LED behaviour	Number of modules 1		
SXMC02		Equipped with 3 LED lights: green, red and yellow Consumption: 0.377 W - 31.4 mA (12 V =)	1		

# NEMO SX: energy management system

## connection and configuration



Conform to IIEC/EN 61131-2 (Programmable controllers)  
 NEMO SX energy management system enables to measure, control and visualize the state of 4 rail mounting protection devices (MCBs, RCCBs, RCBs, etc..) or head equipment, locally ("Stand alone" ) or remotely. All the modules of the system are equipped with two specific communication ports: one at the backside (for communication rail) and one underneath (for patch cords).  
 Power supply with specific module.

Remote configuration possible with the help of the Energy Management Configuration Software, available for free download via IME web site (giving also access to a 30-day trial version of Energy Management Software)

Cat. No	Connection accessories	Cat. No	Stand alone configuration module
	<p><b>Communication rails</b>            To be fitted on rail or spacer            Allows data transmission between the different modules of NEMO SX energy supervision system</p> <p>SXAR18 18 modules            SXAR24 24 modules            SXAR36 36 modules</p> <p><b>Plastic cover for communication rail</b>            Must be used for protection of the unused parts of the communication rail. Can be cut to the required length.            Fixing: direct clip on to the rail            Length: 36 modules</p> <p><b>Communication patch cords</b>            Allows data transmission between the different modules of NEMO SX energy supervision system            Can be used instead of communication rails or to create a link between two rows (individually connected with communication rails)</p> <p>SXAC250 Length 250 mm            SXAC500 Length 500 mm            SXAC1000 Length 1000 mm</p> <p><b>Communication patch cord connector</b>            Enables to extend communication patch cords length by clipping them together            Max. length: 3 m</p>		<p><b>Optional module for "stand alone" supervision need</b>            SXV01 Enables to configure, test and control NEMO SX energy management system and to visualize supervision data            No computer or IP connection required            Consumption: 0.438 W - 36.5 mA (12 V =)</p>
			<p><b>Remote configuration and supervision</b>            Allows remote configuration, test, control and visualization of data collected from EMDX<sup>3</sup> electrical energy meters and multi-function measuring units and NEMO SX energy management system on one computer connected to the network</p> <p>SXS32 Software licence agreement (user key) for 32 Modbus addresses or 32 pulse modules            SXS255 Software licence agreement (user key) 255 Modbus addresses or 255 pulse modules</p> <p><b>Energy management multi-support web servers</b>            Allow remote configuration, test, control and visualization, via a web browser on PCs, smartphones, web viewers, tablet computers, of data collected from: protection devices, electricity meters and multi-function measuring units and NEMO SX energy management system</p> <p>SXWS10 For 10 Modbus addresses or 32 pulse modules            SXWS32 For 32 Modbus addresses or 32 pulse modules            SXWS255 For 255 Modbus addresses or 32 pulse modules</p>
	<p><b>Power supply module</b>            SXAA230 500 mA 12 V = stabilized power supply module for CX3 energy management system</p>		<p><b>Communication interfaces</b>            SXI485 RS485 / NEMO SX energy management system conversion            Consumption: 0.344 W - 28.7 mA (12 V =)            SXIIP RS485 / Ethernet conversion (for connection to an IP network)</p>



Via Travaglia, 7  
20094 Corsico (MI)  
☎ : +39 02 44 878.1  
Fax +39 02 45 03 448  
[info@imeitaly.com](mailto:info@imeitaly.com)  
[www.imeitaly.com](http://www.imeitaly.com)